

ADAPTIX™ ASJ-KT-150

Installation, Operations & Maintenance Guide

Compatible with Kurt DX6 (Rev A) Vise



For more information scan QR code
or visit norgrenworkholding.com

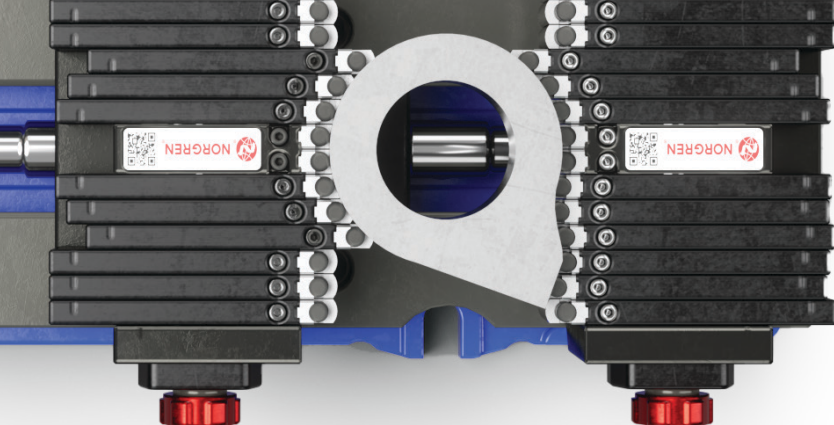

ADAPTIX™ Installation, Operations & Maintenance Guide

ASJ-KT-150

Things to Know Before You Get Started

1. The ADAPTIX™ ideally performs as a stationary work-holding device in a variety of operations utilizing a single station, fixed-jaw vise.
2. The manufacturer accepts no liability for any damage arising from misuse.
3. Avoiding misuse is necessary for safety, satisfactory performance, and product life.
4. Examples of misuse can include, but are not limited to:
 - Clamping workpieces that extend largely beyond the width of the jaws
 - Clamping tall workpieces with insufficient contact depth or without additional fixturing
 - Clamping thin workpieces that are insufficiently supported or without additional fixturing
 - Clamping workpieces without locking the fingers to the minimum specified torque
 - Supporting workpieces via the fingertip steps without performing the initial dressing procedure
5. To assure safety, satisfactory performance, and product life, only use original parts or parts approved by the manufacturer.
6. Always use the supplied torque screwdriver when changing and replacing fingertips and studs. Damage may occur if the fingertips and studs are not sufficiently tightened.
7. Installation, operation, monitoring and maintenance must be carried out by personnel with relevant machining qualifications.
8. Personal protective equipment must be worn when operating the device.

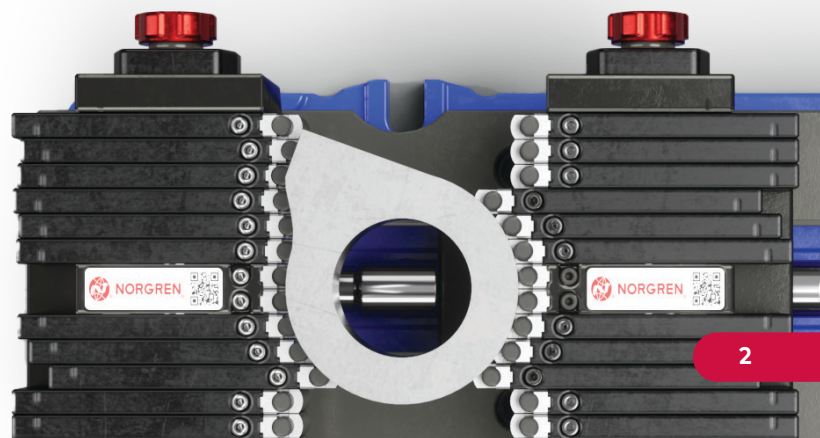

Description

The ADAPTIX™ system replaces equivalent size soft jaws for common machining operations by mounting directly to your existing vise base.

The ADAPTIX™ uses two sets of adjustable fingers within a specially designed housing that can be clamped to hold a designated part profile. Interchangeable studs make contact with a workpiece while the modular tips act as a shelf to properly fixture the workpiece in the vertical Z-axis.

The ADAPTIX™ finger tips additionally function like parallels via the integrated steps. The steps support the workpiece from the bottom while the studs contact the workpiece along its profile. The studs transfer the force generated from the vise into the workpiece via the working surface.

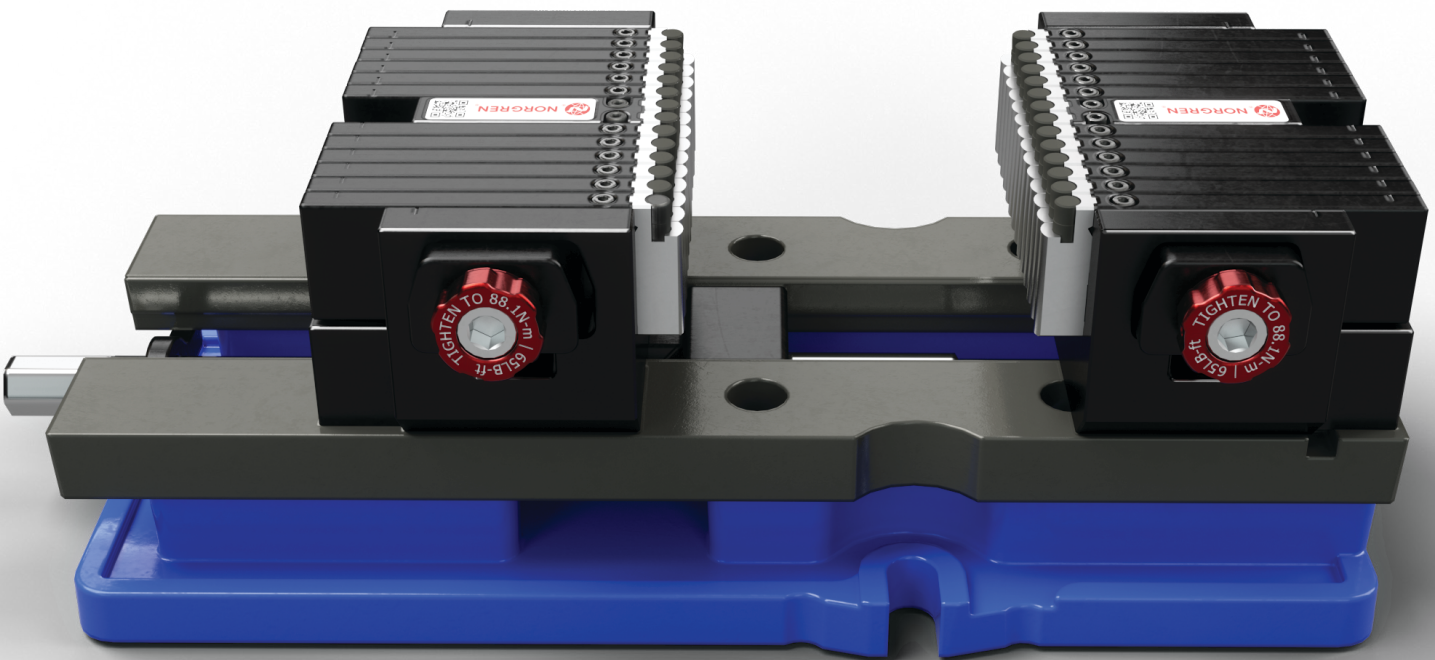

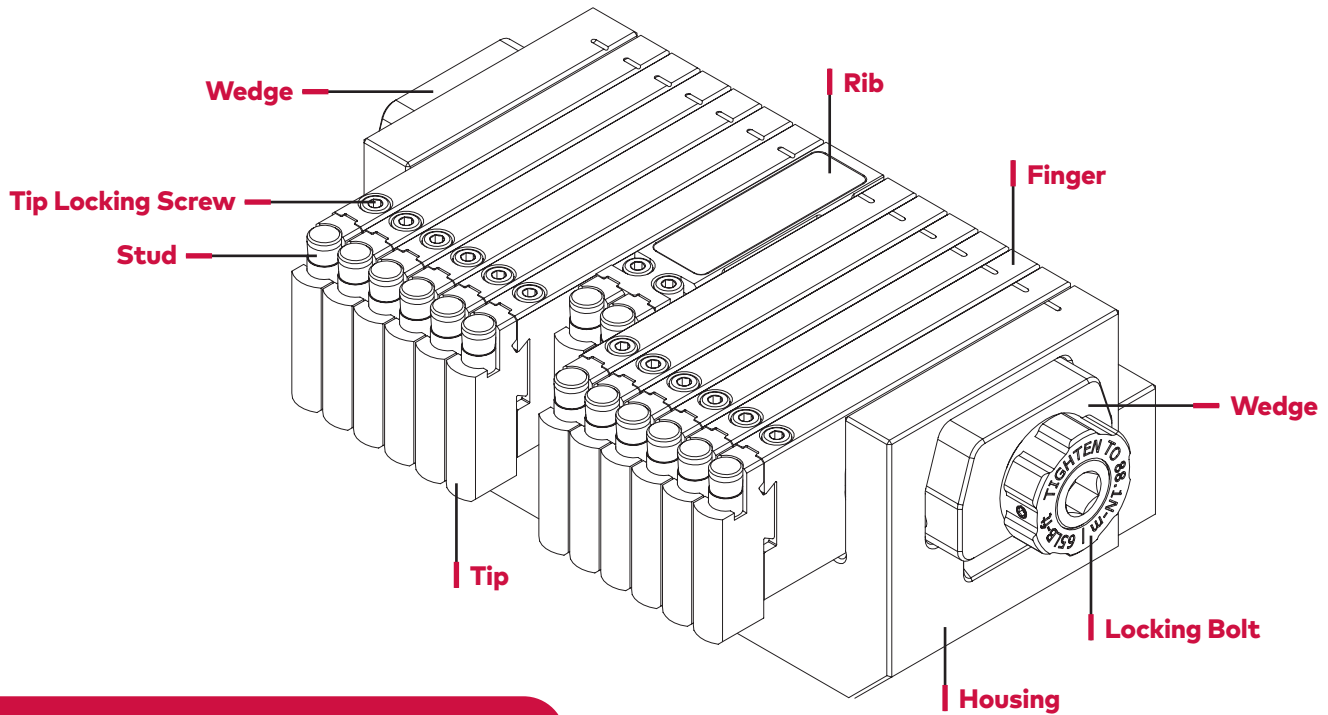

ADAPTIX™ Terminology

| | |
|-----------------------|--|
| Housing | Frame of the ADAPTIX™ system, named for its function of housing the fingers. |
| Finger | Load Bearing body of the clamping mechanism of the ADAPTIX™ |
| Fingerpack | One set of six fingers. Each ADAPTIX™ jaw contains two fingerpacks, differentiated by Left and Right. |
| Tip | Workpiece interface, fastened to the fingers and rib, interchangeable based on user needs and considerations. |
| Rib | Stationary centerpiece of the housing, provides rigidity and additional positional support for the system. |
| Side Plate | Stationary ends of the housing that locate the fingers and facilitate the use of the locking system. |
| Locking Bolt | High-Grade Alloy Steel bolt used to clamp down the locking system |
| Locking System | Transmits clamping force between the locking screw and the clamping mechanism of the ADAPTIX™ |
| Clamping | Torquing down the vise jaws to constrain a workpiece. |
| Locking | Torquing the locking bolt down to specified parameters to set the position of the ADAPTIX™ fingers for clamping. |
| Drift | Unintended displacement of the finger(s) from their originally intended position. |
| Rib Contact | Workpiece is being held by both ribs. |

General Installation

Preparing Your (Kurt DX6) Vise

1. Remove the chip guard.
2. Remove the free jaw set screw with a ¼" hex drive wrench.
3. Pivot the free jaw up and towards the fixed jaw to remove it.
4. Remove the (4) fixed jaw screws with a 3/8" hex drive wrench.
5. Lift the fixed jaw straight up to remove it.

Installing the ADAPTIX™ Adaptor Plate

1. Remove the ADAPTIX™ adaptor plate from the bottom of the ADAPTIX™ fixed jaw by loosening the jaw set screw with a ¼" hex drive wrench.
2. Install the ADAPTIX™ adaptor plate on the vise by dropping it in place of the fixed jaw.
3. Use (2) 7/16 SHCS supplied with the ADAPTIX™ to fix the adaptor plate in place.
4. Torque to 95N-m (70 ft-lbs).

Installing the ADAPTIX™ Jaws

1. Apply a generous amount of the supplied grease on to the round AND flat surface of the spherical segment for the free side.
2. Install the spherical segment into the socket on the inside of the free side of the ADAPTIX™ jaw housing.
3. Orient the ADAPTIX™ jaws so that the fingertips are facing toward the center of the vise.
4. Install the ADAPTIX™ jaws onto the ADAPTIX™ adaptor plate and vise carriage by pivoting it down and away from the center of the vise.
5. Tighten the jaw set screws with a ¼" hex drive wrench.
 - a. Torque the fixed jaw set screw to 68 N-m (50 ft-lbs).
 - b. Tighten free jaw set screw until snug and then back off slightly to desired feel.

IMPORTANT: Verify the set screw head is just below or above the surface of the free jaw. If it is deep, the spherical segment is not seated. Remove the jaws and repeat step 4 taking care when inserting the spherical segment.

Reversing Lock Position

The ADAPTIX™ locking bolt head can be reversed to access easier in certain setups or machines.

1. Remove the locking bolt with a 10mm hex drive wrench or by hand via the knob.
2. Remove the driving wedges and reverse their positions.
3. Reinstall the locking bolt.

General Installation Cont.

Installing Fingertips

1. Using the supplied 3mm hex drive torque screwdriver, loosen the tip locking screw until the clamp is below the bottom surface of the finger clamp pocket.
2. Orient the fingertip so the stud mating hole is upwards.
3. Install the fingertip dovetail into the mating feature of the finger or housing. The tip should lay flat against the mating surface and the key should be engaged fully.
4. Tighten the tip locking screw with the 3mm hex drive torque screwdriver until the screwdriver makes an audible "click".

Dressing Fingertips

Before work can be performed with the ADAPTIX™ jaws, the fingertip steps must first be first dressed on a milling machine with a cutting tool to assure the workpiece will lay flat across both jaws.

1. Install the fingertips on both jaws without studs
2. Install the vise into a vertical milling machine or other precision machining center of your choice.
3. Place a 3-2-1 block or a ¼" parallel between the jaws, resting flat on the vise ways.
4. Clamp the vise down against the 3-2-1 block
IMPORTANT: The 3-2-1 block should be in contact with the housings only and not the fingertips
5. Using a felt tip marker or some other marking method, create a witness mark across the steps of the fingertips.
6. Perform a 0.13mm (0.005") deep skim cut with a cutting tool (12mm (0.5") recommended) across both sets of fingertips.
7. Inspect the steps and assure no witness marks remain. If any remain, perform an additional 0.13mm (0.005") deep skim cut.

Fingertip Installation Order

After the fingertips are dressed, it is important that they remain matched to both the finger they are fixed to as well as the jaw they are on. If the tips are removed, they can be placed back onto the same finger and their calibration will be maintained. If the finger and fingertips are removed as an assembly, they can be placed in any position on the same jaw and their calibration will be maintained.

Re-Dressing

The fingertips can be re-dressed as many times as the fingertip step relief can accept. With each skimming, the fingertip step height will increase.

Fingertip re-dressing will be necessary under the following conditions:

- A fingertip is replaced in a set that has been previously dressed.
- Dressed fingertips are scrambled from their original order.
- Dressed fingertips and finger assemblies are placed on different jaws.

General Installation Cont.

Installing Studs

1. Orient the stud so that the threaded hole is facing down, and the working surface is pointing in the desired direction.
2. Insert the stud into the mating hole on the fingertip.
3. The stud should be flush or below the top surface of the fingertip. If it isn't, rotate the stud slightly and it will drop in place.
4. Install the supplied M4 SHCS into the bottom of the fingertip
5. Tighten the stud screw with the 3mm hex drive torque screwdriver until the screwdriver makes an audible "click".

Configuring Jaws

For certain operations, it might be desirable to utilize the ADAPTIX™ jaw as a standard square jaw to grip square workpieces. Pushing the fingers completely backward until the fingertips touch the housing and locking will create a square surface that can be used like a traditional vise jaw.

Adjusting Drag Force

Tightening and loosening the locking bolt via the thumb knob will increase and decrease the drag on the fingers in each jaw.

Locking Fingers

1. Hand-tighten the locking bolt via the thumb knob to fix the fingers in place.
2. With a 10mm hex drive bit and a torque wrench, tighten the bolt to the specified minimum torque. **IMPORTANT:** Always use a torque wrench to assure the locking bolt is at the minimum torque. Do not clamp the vise without assuring the locking bolt is at minimum torque.

IMPORTANT: Make sure the part is removed from vise before torquing.

Maintenance

When following the outlined instructions; the ADAPTIX™ can be completely disassembled and reassembled in end-user environments.

NOTE: This section excludes the disassembly of fingertips and studs, for fingertip and stud disassembly instructions, refer to earlier sections

1. Ensure the jaw(s) are not under clamping tension, and the locking bolt is loose/not under tension. Note which side the bolt head knob is installed on.
2. Unthread the locking bolt completely, the driving wedges will be able to be removed from the housing. Set the bolt and driving wedges aside.
3. From either side of the jaw, push the locking tube out from the center of the jaw.

Maintenance Cont.

4. Remove the locking tube and the driven wedges from both sides of the jaw. Set the parts aside.
5. Make sure to maintain the order of the fingers. Lift the fingers out from the saddle of the jaw, one fingerpack at a time. Keep the left fingerpack and right fingerpack separate to avoid mixing.
6. For the jaw to be removed, the mounting mechanism must first be deactivated. Loosen and back out the set screw on the back face of the jaw, so that the set screw will not interfere with the removal of the jaw from the vise.
7. Lift the housing out from the jaw mount position on the vise.
8. The ADAPTIX™ system is considered completely stripped and removed from the vise.

Cleaning & Lubrication

NOTE: The ADAPTIX™ system must be field stripped prior to cleaning and lubrication.

- Using a low-pressure air source (30 PSI or lower) blow off, then wipe dry all parts.
- During reassembly, apply low-friction extreme pressure grease to the angled surfaces of both wedges, the threads on the threaded wedges, and both sides of the locking bolt washer. Also make sure to lubricate the hemispherical segment and socket inside of free housing.

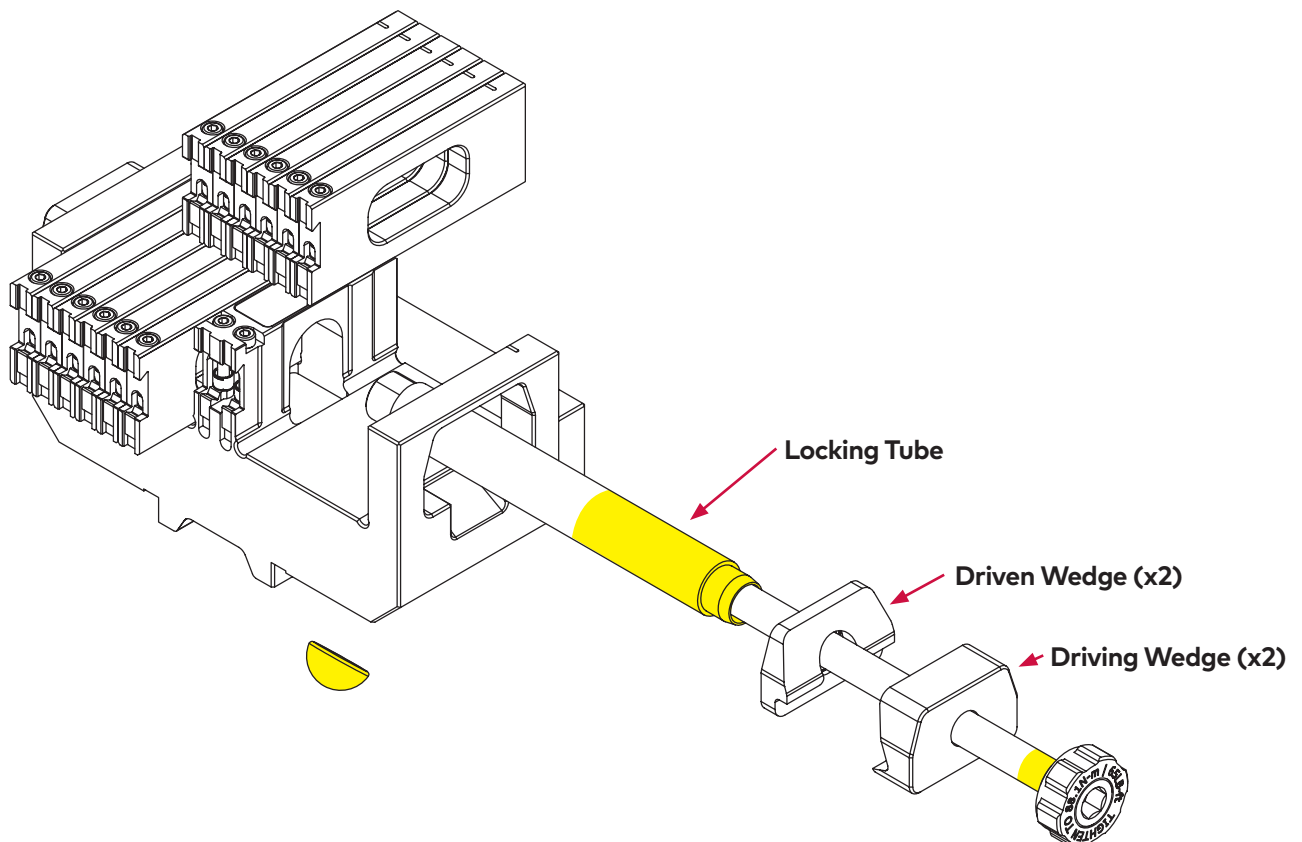

Part Quality & Finish

We understand that our customers all over the world have a variety of part quality requirements and these requirements must be maintained to meet production targets. To best accommodate to this range of needs and provide proper part engagement, the ADAPTIX™ System leverages multiple styles of studs.



Round Studs

The ADAPTIX™ Round Studs are the standard for our solution, consisting of a higher hold taper profile. With our hardened A2 Tool Steel material and indexable hex-shaped bottom design, you can enjoy greater capability and extended tool life.



Serrated Studs

The ADAPTIX™ Serrated Studs are crafted from hardened A2 Tool Steel and specially designed for high hold requirements. Also, due to the serration heights, our Serrated Studs can grip at any of the step heights on your unit. This can be great for Castings, Flame Cut parts, Rough Saw Parts, and even Teflon.



Free Rotating Studs

The ADAPTIX™ Free Rotating Studs are a top option for any shop in need of a versatile workholding solution. With this stud's unique D-shape profile, it has the ability to rotate about its primary axis, allowing it to normalize to any surface upon part contact. This specific style allows more surface area contact with the part, making it less likely to mark the workpiece.

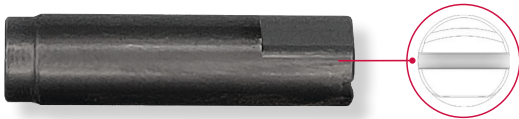

Concave Studs

The ADAPTIX™ Concave Studs are a top option for any shop in need of a versatile workholding solution for round parts. When used correctly with round curvature surfaces, there is virtually zero surface marring visible.



For more info on our studs or other ADAPTIX™ accessories, visit us at www.norgrenworkholding.com

Join Our Community

 norgrenworkholding.com

 [instagram.com/adaptixbynorgren](https://www.instagram.com/adaptixbynorgren)

 [linkedin.com/showcase/norgren-workholding](https://www.linkedin.com/showcase/norgren-workholding)

 [facebook.com/adaptixbynorgren](https://www.facebook.com/adaptixbynorgren)

 [youtube.com/@adaptixbynorgren](https://www.youtube.com/@adaptixbynorgren)



For more information scan QR code
or visit norgrenworkholding.com

ADAPTIX™
by  **NORGREN**

Norgren operates four global centers of technical excellence and a sales and service network in 50 countries, as well as manufacturing capability in Brazil, China, Czech Republic, Germany, India, Mexico, UK and the USA.

For information on all Norgren companies visit

www.norgren.com

Supported by distributors worldwide.