

ADAPTIX™ **ASJ-RMMSR-150** **Installation,** **Operations &** **Maintenance Guide**

Compatible with Rohm MSR 150 Vise



For more information scan QR code
or visit norgrenworkholding.com



ADAPTIX™ Installation, Operations & Maintenance Guide ASJ-RMMSR-150

Things to Know Before You Get Started

1. The ADAPTIX™ ideally performs as a stationary work-holding device in a variety of operations utilizing a single station, fixed-jaw vise.
2. The manufacturer accepts no liability for any damage arising from misuse.
3. Avoiding misuse is necessary for safety, satisfactory performance, and product life.
4. Examples of misuse can include, but are not limited to:
 - Clamping workpieces that extend largely beyond the width of the jaws
 - Clamping tall workpieces with insufficient contact depth or without additional fixturing
 - Clamping thin workpieces that are insufficiently supported or without additional fixturing
 - Clamping workpieces without locking the fingers to the minimum specified torque
 - Supporting workpieces via the fingertip steps without performing the initial dressing procedure
5. To assure safety, satisfactory performance, and product life, only use original parts or parts approved by the manufacturer.
6. Always use the supplied torque screwdriver when changing and replacing fingertips and studs. Damage may occur if the fingertips and studs are not sufficiently tightened.
7. Installation, operation, monitoring and maintenance must be carried out by personnel with relevant machining qualifications.
8. Personal protective equipment must be worn when operating the device.

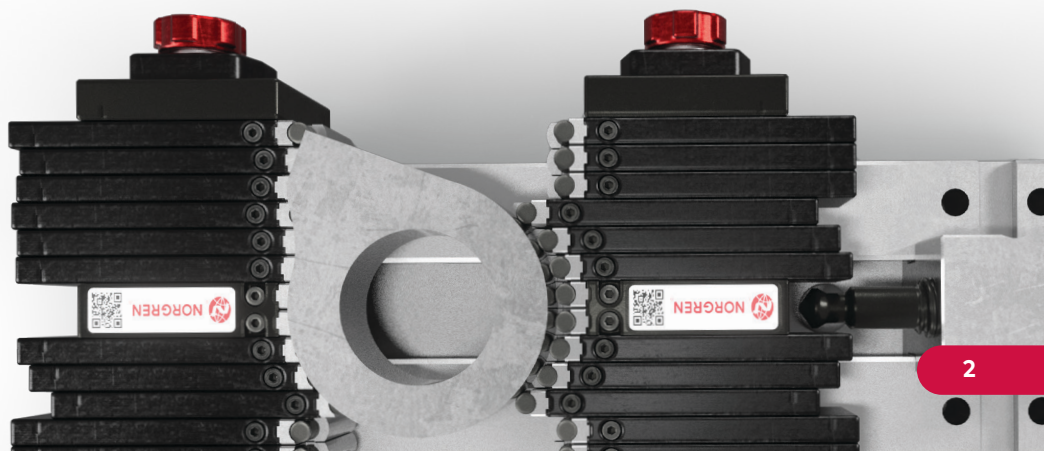

Description

The ADAPTIX™ system replaces equivalent size soft jaws for common machining operations by mounting directly to your existing vise base.

The ADAPTIX™ uses two sets of adjustable fingers within a specially designed housing that can be clamped to hold a designated part profile. Interchangeable studs make contact with a workpiece while the modular tips act as a shelf to properly fixture the workpiece in the vertical Z-axis.

The ADAPTIX™ fingers additionally function like parallels via the integrated steps. The steps support the workpiece from the bottom while the studs contact the workpiece along its profile. The studs transfer the force generated from the vise into the workpiece via the working surface.

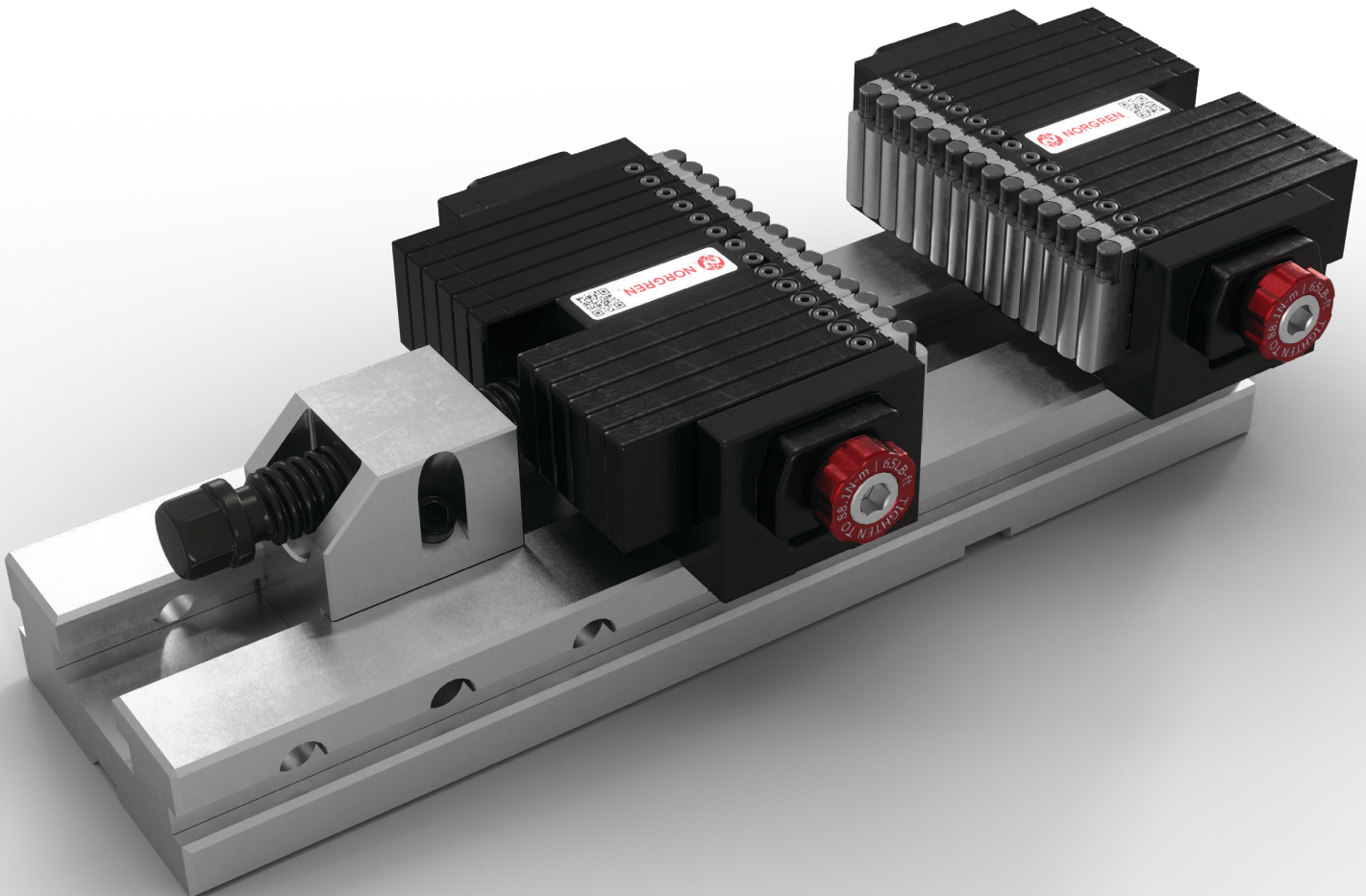

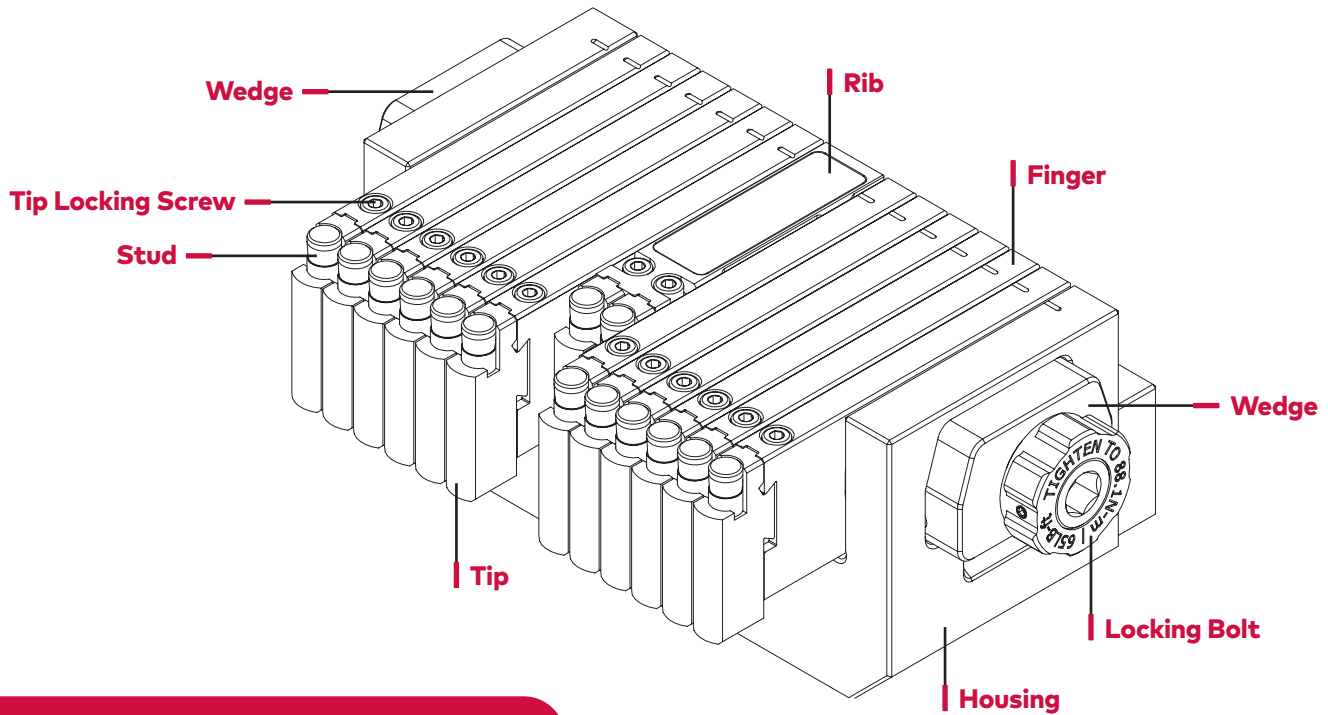

ADAPTIX™ Terminology

Housing	Frame of the ADAPTIX™ system, named for its function of housing the fingers.
Finger	Load Bearing body of the clamping mechanism of the ADAPTIX™.
Fingerpack	One set of six fingers. Each ADAPTIX™ jaw contains two fingerpacks, differentiated by Left and Right.
Tip	Workpiece interface, fastened to the fingers and rib, interchangeable based on user needs and considerations.
Rib	Stationary centerpiece of the housing, provides rigidity and additional positional support for the system.
Side Plate	Stationary ends of the housing that locate the fingers and facilitate the use of the locking system.
Locking Bolt	High-Grade Alloy Steel bolt used to clamp down the locking system.
Locking System	Transmits clamping force between the locking screw and the clamping mechanism of the ADAPTIX™
Clamping	Torquing down the vise jaws to constrain a workpiece.
Locking	Torquing the locking bolt down to specified parameters to set the position of the ADAPTIX™ fingers for clamping.
Drift	Unintended displacement of the finger(s) from their originally intended position.
Rib Contact	Workpiece is being held by both ribs.

General Installation

Preparing the ASJ-RMMSR-150

1. Remove the screws on fixed jaws by loosening the top mount screw with a 12mm hex drive wrench.
2. Remove the fixed jaw from the housing.
3. Remove the free jaw by:
 - a. Pulling out the stop pin from the clamping block.
 - b. Pulling both the clamping block and the free jaw entirely out from the back of the vise.
4. Clean, wipe down and blow dry the vise. Ensuring the removal of any contaminants.

Installing the Fixed Jaw

For bolt-mount vises, the ADAPTIX™ uses the original equipment threaded holes to mount directly to the vise using an anchoring pull-stud system. The process of installation for an individual jaw is outlined below, use this process for all jaws that use Anchoring Posts:

1. Remove the OEM jaw from the vise by unthreading all fasteners. Store OEM jaws and fasteners with proper rust-preventative measures.
2. Clean and wipe down the vise and its threads, using a degreasing cleaner (isopropyl alcohol preferred), cotton cloth and blow dry with pressurized air below 30 PSIG. Ensure the vise and threads are free of debris.
3. Gather the Anchoring Posts from the ADAPTIX™ packaging, there will be (4) posts per bolt-mounted jaw, the threads shall match the OEM threads of the vise.
4. Some vise manufacturers have the jaw's fastener holes travel through the key of the vise. If your OEM vise is one of these configurations, your unit will have the necessary amount of Extended Anchoring Posts to fit into the key, make sure to differentiate these Extended Posts from the regular Posts before installation.
5. Using fresh oil, or grease. Lubricate the vises' threaded holes and surfaces around the holes, this is to protect the interface from corrosion.
6. Hand thread the (4) posts into the holes on the vise, bottom out the threads on the underhead of the post.
7. Extended Anchoring posts will sit inside of the vise keyway, they must sit flush with the posts that are sitting on the viseway.
8. Using an 8mm Hex bit (**Caution:** Use a 3/8" [10mm] drive size or larger on your socket) torque each of the posts down, individually, to the torque value on the top of the Anchoring Post.

a. **Caution:** This thread is a 'Hard Joint', do not exceed the recommended torque values, as stressing them past recommended torque could result in failure of the posts or the ADAPTIX™ soft jaw.

b. Torque Values by Size:

Thread Size / Torque Value (N-m)

M10 / 45

M12 / 55

M14 / 65

M16 / 75

General Installation Cont.

9. Taking a jaw assembly, place the correct side (Fixed or Free) on top of the Anchoring Posts, ensuring that the fingers are aimed inwards at the center of the vise. The housing must sit flat on the viseway, verify with a feeler gage under .030mm (.0015") if possible.
10. Taking (4) Wedge Pins and the Pin Tool from the packaging, thread (1) Wedge Pin onto the thread of the Pin Tool, by hand.
11. Mate the pin slot with the key on the tool. The pin will be retained by magnets.
12. Using the tool, insert the pin into any of the holes on the side of the jaw housing, mating the key on the tool with the matching slot on the housing. This will align the pin in the correct orientation, the pin will not insert at any other rotation.
13. Using a mallet or your hand, push the screw into the hole, engaging the pin with the Anchoring Post.
14. Fully unthread the screw from the pin, either by hand or with a 3mm hex tool.
15. Insert the other pins using the same process.
16. After inserting all pins, take (4) Set Screws from the packaging, thread (1) in each hole, bottoming the threads out by hand.
17. After all (4) set screws are hand tight, use a 6mm hex bit to torque each of the (4) set screws down to 10 N-m, utilizing a star pattern.
18. Retorque all (4) screws down to 10 N-m to mitigate any movement from installing opposing screws.
19. Verify correct install again with a .030mm feeler gage around the perimeter of the jaw.
20. Jaw has been installed correctly.

Installing the Free Jaw

1. To install the free jaw on the vise, verify you have the clamping bolt, the clamping block and the screws which go into the block.
2. Insert the free housing onto the vise by aligning the bottom part of the housing with the viseway t-slot and insert
3. Insert the bearing side of the clamping bolt into the stop block thread, do not yet insert the stop block into the vise t-slot.
4. Engage the bolt into the back of the free jaw and push it upwards in the slot. This mates the bolt with the back of the free housing.
5. Take both the bolt and the stop block and insert it into the vise t-slot
6. Lock the stop block by inserting the stop pin at the discrete opening width.
7. Installation complete, the jaws will function with the same method as the original equipment.

Reversing Lock Position

The ADAPTIX™ locking bolt head can be reversed to make access easier in certain setups or machines.

1. Remove the locking bolt with a 10mm hex drive wrench or by hand via the knob.
2. Remove the driving wedges and reverse their positions.
3. Reinstall the locking bolt.

General Installation Cont.

Installing Fingertips

1. Using the supplied 3mm hex drive torque screwdriver, loosen the finger clamp screw until the clamp is below the bottom surface of the finger clamp pocket.
2. Orient the fingertip so the stud mating hole is upwards.
3. Install the fingertip dovetail into the mating feature of the finger or housing. The tip should lay flat against the mating surface and the key should be engaged fully.
4. Tighten the finger clamp with the 3mm hex drive torque screwdriver until the screwdriver makes an audible "click".

Dressing Fingertips

Before work can be performed with the ADAPTIX™ jaws, the fingertip steps must first be first dressed on a milling machine with a cutting tool to assure the workpiece will lay flat across both jaws.

1. Install the fingertips on both jaws without studs
2. Install the vise into a vertical milling machine or other precision machining center of your choice.
3. Place a piece of stock or a ¼" parallel between the jaws, resting flat on the vise ways.
4. Clamp the vise down against the piece of stock or parallel laid flat.
IMPORTANT: The piece should be in contact with the housings only and not the fingertips
5. Using a felt tip marker or some other marking method, create a witness mark across the steps of the fingertips.
6. Perform a 0.13mm (0.005") deep skim cut with a cutting tool (12mm (0.5") recommended) across both sets of fingertips.
IMPORTANT: Do not adjust the z-depth between cutting the fixed and free fingertip sets
7. Inspect the steps and assure no witness marks remain. If any remain, perform an additional 0.13mm (0.005") deep skim cut.

Fingertip Installation Order

After the fingertips are dressed, it is important that they remain matched to both the finger they are fixed to as well as the jaw they are on. If the tips are removed, they can be placed back onto the same finger and their calibration will be maintained. If the finger and fingertips are removed as an assembly, they can be placed in any position on the same jaw and their calibration will be maintained.

Re-Dressing

The fingertips can be re-dressed as many times as the fingertip step relief can accept. With each skimming, the fingertip step height will increase.

Fingertip re-dressing will be necessary under the following conditions:

- A fingertip is replaced in a set that has been previously dressed.
- Dressed fingertips are scrambled from their original order.
- Dressed fingertips and finger assemblies are placed on different jaws.

General Installation Cont.

Installing Studs

1. Orient the stud so that the threaded hole is facing down, and the working surface is pointing in the desired direction.
2. Insert the stud into the mating hole on the fingertip.
3. The stud should be flush or below the top surface of the fingertip. If it isn't, rotate the stud slightly and it will drop in place.
4. Install the supplied M4 SHCS into the bottom of the fingertip
5. Tighten the stud screw with the 3mm hex drive torque screwdriver until the screwdriver makes an audible "click".

Configuring Jaws

For certain operations, it might be desirable to utilize the ADAPTIX™ jaw as a standard square jaw to grip square workpieces. Push the fingers completely backward until the fingertips stop on the housing face and lock them into place. This will create a square surface that can be used like a traditional softjaw.

Adjusting Drag Force

Tightening and loosening the locking bolt via the thumb knob will increase and decrease the drag on the fingers in each jaw.

Locking Fingers

1. Hand-tighten the locking bolt via the thumb knob to fix the fingers in place.
2. With a 10mm hex drive bit and a torque wrench, tighten the bolt to the specified minimum torque. **IMPORTANT:** Always use a torque wrench to assure the locking bolt is at the minimum torque. Do not clamp the vise without assuring the locking bolt is at minimum torque.

IMPORTANT: Make sure the part is removed from vise before torquing.

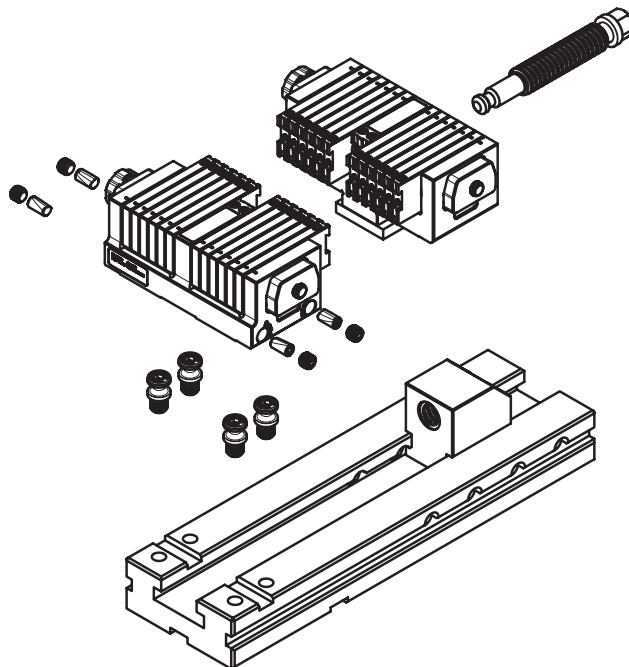

Maintenance

When following the outlined instructions; the ADAPTIX™ can be completely disassembled and reassembled in end-user environments.

NOTE: This section excludes the disassembly of fingertips and studs, for fingertip and stud disassembly instructions, refer to earlier sections

1. Ensure the jaw(s) are not under clamping tension, and the locking bolt is loose/not under tension. Note which side the bolt head knob is installed on.
2. Unthread the bolt head knob completely, the driving wedges will be able to be removed from the housing. Set the bolt and driving wedges aside.
3. From either side of the jaw, push the locking tube out from the center of the jaw.
4. Remove the locking tube and the driven wedges from both sides of the jaw. Set the parts aside.
5. Make sure to maintain the order of the fingers, lift the fingers out from the saddle of the jaw, one fingerpack at a time. Keep the left fingerpack and right fingerpack separate to avoid mixing.
6. For the jaw to be removed, the mounting mechanism must first be inactivated. Loosen and back out the set screw on the back face of the jaw, so that the set screw will not interfere with the removal of the jaw from the vise.
7. Lift the housing out from the jaw mount position on the vise.
8. The ADAPTIX™ system is considered completely stripped and removed from the vise.

Cleaning & Lubrication

NOTE: The ADAPTIX™ system must be field stripped prior to cleaning and lubrication.

- Using a low-pressure air source (30 PSI or lower) blow off, then wipe dry all parts.
- During reassembly, apply low-friction extreme pressure grease to locking bolt threads, locking bolt washer/underhead of bolt.

Part Quality & Finish

We understand that our customers all over the world have a variety of part quality requirements and these requirements must be maintained to meet production targets. To best accommodate to this range of needs and provide proper part engagement, the ADAPTIX™ System leverages multiple styles of studs.



Round Studs

The ADAPTIX™ Round Studs are the standard for our solution, consisting of a higher hold taper profile. With our hardened A2 Tool Steel material and indexable hex-shaped bottom design, you can enjoy greater capability and extended tool life.



Serrated Studs

The ADAPTIX™ Serrated Studs are crafted from hardened A2 Tool Steel and specially designed for high hold requirements. Also, due to the serration heights, our Serrated Studs can grip at any of the step heights on your unit. This can be great for Castings, Flame Cut parts, Rough Saw Parts, and even Teflon.



Free Rotating Studs

The ADAPTIX™ Free Rotating Studs are a top option for any shop in need of a versatile workholding solution. With this stud's unique D-shape profile, it has the ability to rotate about its primary axis, allowing it to normalize to any surface upon part contact. This specific style allows more surface area contact with the part, making it less likely to mark the workpiece.



For more info on our studs or other ADAPTIX™ accessories, visit us at www.norgrenworkholding.com

Join Our Community

 norgrenworkholding.com

 [instagram.com/adaptixbynorgren](https://www.instagram.com/adaptixbynorgren)

 [linkedin.com/showcase/norgren-workholding](https://www.linkedin.com/showcase/norgren-workholding)

 [facebook.com/adaptixbynorgren](https://www.facebook.com/adaptixbynorgren)

 [youtube.com/@adaptixbynorgren](https://www.youtube.com/@adaptixbynorgren)



For more information scan QR code
or visit norgrenworkholding.com

ADAPTIX™
by  **NORGREN**

Norgren operates four global centers of technical excellence and a sales and service network in 50 countries, as well as manufacturing capability in Brazil, China, Czech Republic, Germany, India, Mexico, UK and the USA.

For information on all Norgren companies visit

www.norgren.com

Supported by distributors worldwide.